



MODULUS[®] MS-1

Owner's Guide



INTRODUCTION

The Infinity Modulus MS-1 is a compact, efficient, universal satellite that is ideal for reproducing music or movie soundtracks. With its versatile design, the MS-1 can be placed virtually anywhere, including on a shelf or mounted to a wall using the integrated base/wall-mount bracket.

About This Guide

To start enjoying your new Modulus MS-1, read and then follow all instructions listed in this guide, as well as those found in the owner's manuals of associated components in your audio system. Save all instructions for future reference.

TECHNOLOGY

Modulus loudspeakers incorporate several innovative technologies that, when combined with many hours of subjective listening evaluations and our rigorous engineering standards, result in a loudspeaker that realistically and accurately reproduces the signal source with minimal distortion and coloration.

Ceramic Metal Matrix Diaphragms™ (C.M.M.D.)

For decades, loudspeaker engineers have known that the ideal transducer should be stiff, yet light, and have high internal damping (damping is a material's ability to absorb energy). Infinity's C.M.M.D. transducer is a significant advance in transducer technology. Ceramic, a class of material new to loudspeakers, offers better performance than other materials. Ceramic is stiffer than metals and lighter than plastics and typical composite materials; it also offers improved damping. These ceramic-based transducers take us a giant step closer to the ever-elusive "ideal transducer."

In tweeters, C.M.M.D. technology offers stiffness and damping superior to that of traditional metals and soft-dome materials. In woofer and midrange applications, it offers accurate piston operation over the entire frequency range of the driver, completely eliminating coloration due to cone breakup and dramatically reducing distortion. And when ceramic-metal-matrix transducers are exposed to moisture, sunlight or extreme temperatures, their performance does not deteriorate.

In addition to ceramic diaphragms, all the transducers incorporate magnetic shielding and rigid cast-frames that, through our FEA computer modeling and scanning-laser-vibrometer measurements, have been optimized to reduce resonances. This ensures minimal distortion and incomparable performance.

We hope you enjoyed this brief introduction to the technology featured in the Modulus MS-1. If you would like to further explore Modulus' technology and design, please ask your Infinity dealer for the C.M.M.D. White Paper. The White Paper can also be downloaded from Infinity's Web site at www.infinitysystems.com.

UNPACKING THE SPEAKERS

Carefully unpack the speakers. If you suspect damage from transit, report it immediately to your dealer and/or delivery service. Keep the shipping carton and packing materials for future use. Open the package and verify the following contents:

- (2) Modulus Satellite Speakers With Attached Base

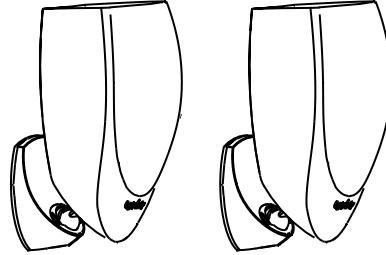

- (2) Modulus Wall-Mount Brackets (attached to Base of Satellites)

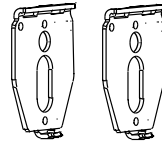

- (1) Wall-Mount Bracket With Bubble Level for Use as Mounting Template.



- Hex Wrench
(Located Behind Rubber Cap of Satellite Base)



- Warranty Statement

PLACEMENT

Before deciding where to place your speakers, survey your room and study Figures 1 and 2.

Stereo

- For best results, place the speakers 6'–8' apart.
- Position each speaker so that the tweeter is at approximately ear level.
- Refer to "Home Theater" below if you also plan to use the speakers for home-theater reproduction.

Home Theater

For front-channel use, place one speaker on the left and another on the right side of the television monitor. Since the speakers are magnetically shielded, you can place them close to the television without the magnetic field distorting the picture.

For rear-channel use, place speakers on bookshelves, or mount to wall, on each side of the listening position. Final placement depends on room acoustics, availability of space and your listening preference (Figure 2).

NOTE: An Infinity powered subwoofer will add impact and realism to both music and film soundtracks. Contact your local Infinity dealer for recommendations on subwoofer models for your application.

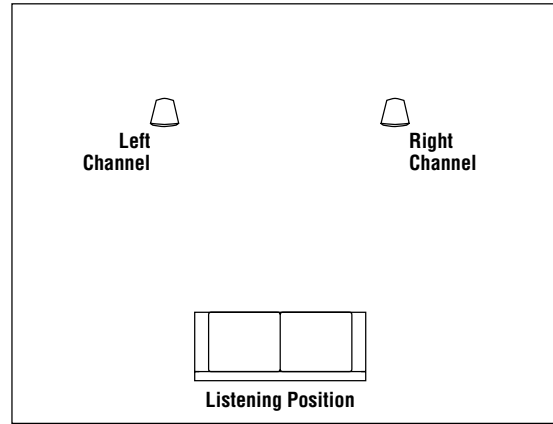

FIGURE 1 – This overhead view shows a typical stereo application.

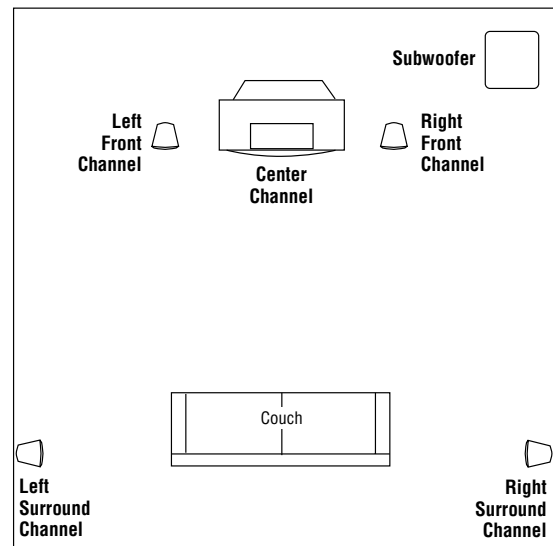

FIGURE 2 – This overhead view shows a typical home theater plan.

INSTALLING THE SATELLITES

For Shelf Placement

1. Remove the Modulus satellites from the box. Remove rubber cover from the base and pull out Allen wrench.

FIGURE 3

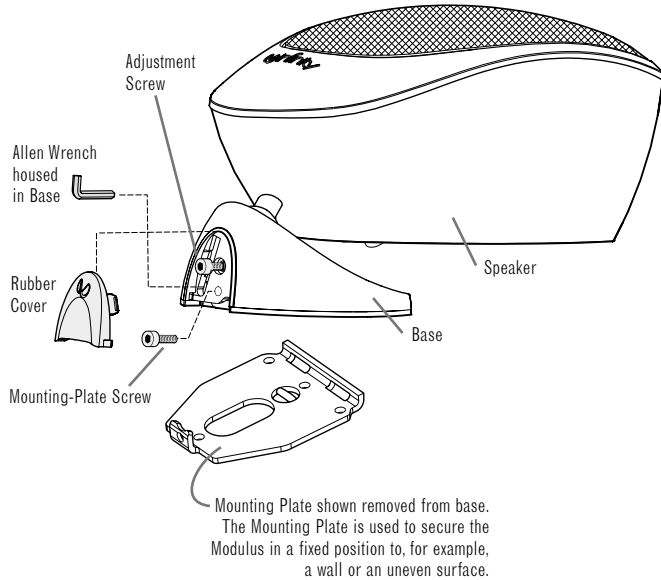

2. Use the Allen wrench to loosen the adjustment screw (as necessary) to allow the mounting ball on the speaker to turn freely in the cup restraint.

FIGURE 4

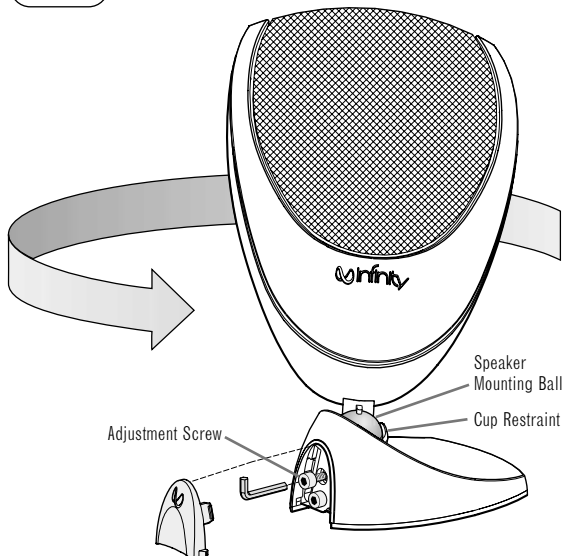

3. Run the speaker wires in through the rear of the base and up through the speaker-wire holes on the left and right sides of the cup restraint (see page 6, Figure 10 for wire connections).

FIGURE 5

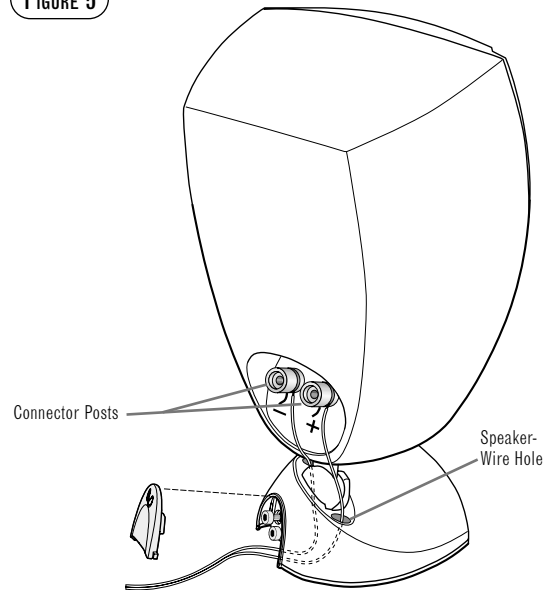

4. Rotate speaker on its base into the shelf placement position as shown below. Tighten the adjustment screw with the Allen wrench (securing the speaker in position) and replace the cover.

FIGURE 6

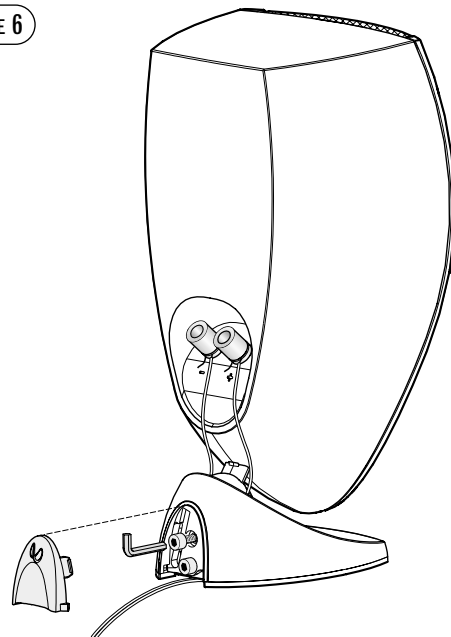

For Wall-Mounting

Note: The customer is responsible for the correct selection and use of mounting hardware (available through hardware stores) that will ensure the proper and safe wall-mounting of the speakers.

1. Remove the Modulus from its box. Remove rubber cover from the base and pull out Allen wrench. Use Allen wrench to remove mounting plate screw and remove mounting plate from base.

FIGURE 7

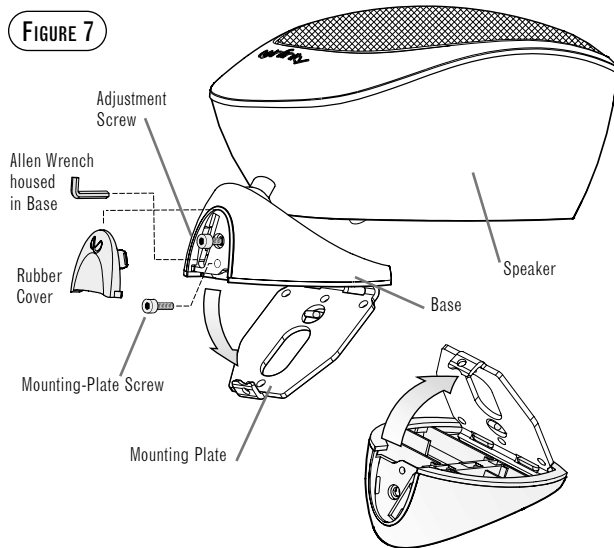

2. Secure the mounting plate to a wall stud using (4) #8-32 wood screws with a minimum 1-1/4" length. If fastened to sheetrock or wallboard with a minimum 1/2" depth, use #8 screws with plastic inserts or anchors. Do not mount directly to sheetrock or wallboard without plastic inserts or anchors designed for #8 screws. One of the mounting plates included with the Modulus MS-1 has a built-in bubble level for leveling while securing to the wall. This mounting plate should be used as a template for mounting the mounting plates that do not include a bubble level.

2a. In cases where you would like to run the speaker wires through the wall, the mounting plate has a center hole for wire access.

FIGURE 8

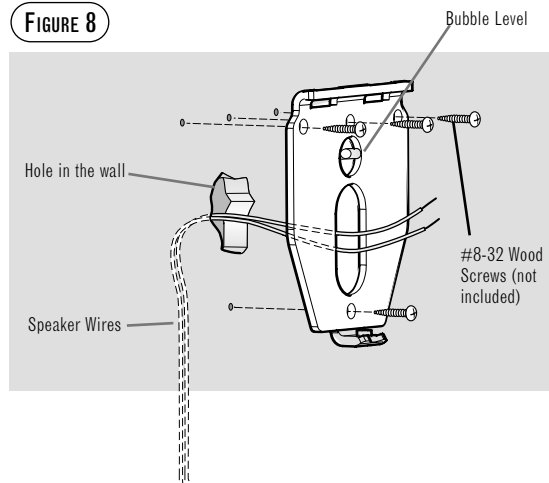

3. Run the speaker wires through the base as shown below. Attach base to mounting plate by slipping the returns on underside of base into slots on the top of the mounting plate and hinging the base downward. Secure base by inserting and tightening mounting plate screw. Tighten adjustment screw, fixing the speaker in position.

FIGURE 9

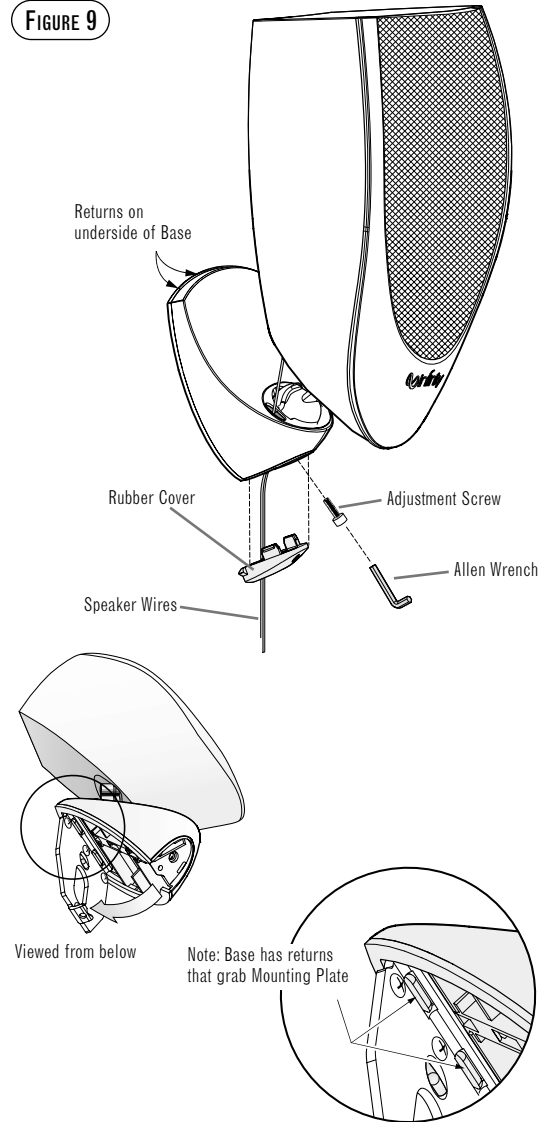

4. Tighten the mounting-plate screw. Insert the Allen wrench back into holder in base and attach rubber cover.

CONNECTIONS

Turn Off All Power

After placing the speakers, you are ready to connect your system. First, turn off all audio-system power. Use high-quality speaker wire to make your connections. Use at least #16-gauge speaker wire with polarity coding. The side of the wire with a ridge or other coding is usually considered positive polarity (i.e., +). Also, consult the owner's manuals that were included with your amplifier or receiver to confirm connection procedures.

Important!

Do not reverse polarities (i.e., + to – or – to +) when making connections. Doing so will cause poor imaging and diminished bass response. Be certain that positive and negative wire strands are completely isolated to avoid short circuits that may damage your equipment.

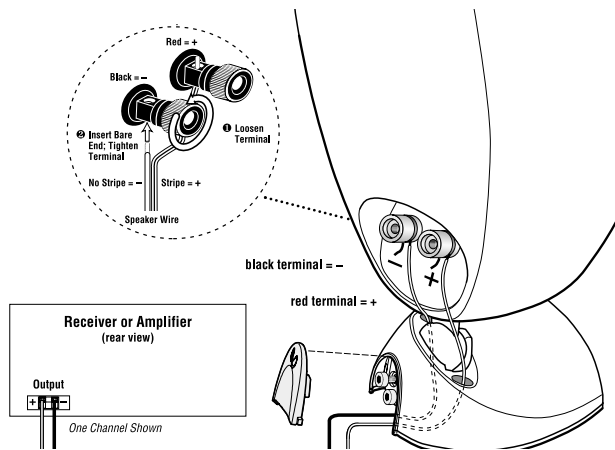

FIGURE 10 – Wiring diagram shows polarity connections for one channel of a stereo or home theater system.

MAINTENANCE AND SERVICE

The speaker enclosures may be cleaned using a soft cloth, dampened with water only, to remove fingerprints or to wipe off dust.

The grilles may be gently vacuumed. Do not use any solvents on the grille.

All wiring connections should be inspected and cleaned or remade periodically. The frequency of maintenance depends on the metals involved in the connections, atmospheric conditions, and other factors, but once per year is the minimum.

If a problem occurs, make sure that all connections are properly made and clean. If a problem exists in one loudspeaker, reverse the connection wires to the left and right system. If the problem remains in the same speaker, then the fault is with the loudspeaker. If the problem appears in the opposite speaker, the cause is in another component or cable. In the event that your Modulus loudspeakers ever need service, contact your local Infinity dealer or Infinity directly at 1-800-553-3332 or www.infinitysystems.com for a service center near you.

SPECIFICATIONS

Modulus MS-1

Frequency Range:	100Hz – 20,000Hz (± 3 dB)
Recommended Amplifier Power Range:	15 – 125 watts
Sensitivity: (2.83V @ 1 meter)	86dB
Nominal Impedance:	8 ohms
Crossover Frequency:	2500Hz, 12dB/Octave
Midrange Driver(s):	4" C.M.M.D., magnetically shielded
High-Frequency Driver:	3/4" C.M.M.D., magnetically shielded
Dimensions (H x W x D):	Shelf position 11" x 5-1/2" x 4-1/2" (279mm x 140mm x 114mm) Wall position 9-3/4" x 5-1/2" x 5-3/4" (248mm x 140mm x 146mm)
Weight:	5.1 lb (2.3kg)

Infinity continually strives to update and improve existing products, as well as create new ones. The specifications and construction details in this and related Infinity publications are therefore subject to change without notice.



H A Harman International Company © 2001 Infinity Systems, Inc., 250 Crossways Park Drive, Woodbury, NY 11797 USA (800) 553-3332 (USA Only) www.infinitysystems.com
Infinity is a registered trademark of Infinity Systems, Inc. Printed in USA 4/01 Part No. MODMS-10M